



**UniRoyal**

# DATASHEET

**Product Name**    **Thick Film Chip Resistors**

---

**Part Name**    **Chip Series**

**File No.**    **SMD-SP-001**

## **Uniroyal Electronics Global Co., Ltd.**

88#, Longteng Road, Economic & Technical Development Zone, Kunshan, Jiangsu, China

Tel    +86 512 5763 1411 / 22 /33

Email    [marketing@uni-royal.cn](mailto:marketing@uni-royal.cn)

Manufacture Plant    Uniroyal Electronics Industry Co., Ltd.

Aeon Technology Corporation

Royal Electronic Factory (Thailand) Co., Ltd.

Royal Technology (Thailand) Co., Ltd.

## 1. Scope

- 1.1 This datasheet is the characteristics of Thick Film Chip Resistors manufactured by UNI-ROYAL.
- 1.2 Small size & light weight.
- 1.3 Reduction of assembly costs and matching with placement machine.
- 1.4 Suitable for both wave & re-flow soldering.
- 1.5 Applications: Navigator (GPS), Mobile Phone, Telecom, PDA, Setbox, Meter.
- 1.6 Compliant with RoHS directive.
- 1.7 Halogen free requirement.

## 2. Part No. System

Part No. includes 14 codes shown as below:

2.1 1<sup>st</sup>~4<sup>th</sup> codes: Part name. E.g.: 01005, 0201, 0402, 0603, 0805, 1206, 1210, 2010, 1812, 2512.

2.2 5<sup>th</sup>~6<sup>th</sup> codes: Power rating.

E.g.: W=Normal Size      "1~G" = "1~16"

Wattage	1/32	3/4	1/2	1/3	1/4	1/8	1/10	1/16	1/20	1
Normal Size	WH	07	W2	W3	W4	W8	WA	WG	WM	1W

If power rating is equal or lower than 1 watt, 5<sup>th</sup> code would be "W" and 6<sup>th</sup> code would be a number or letter.

E.g.: WA=1/10W      W4=1/4W

2.2 7<sup>th</sup> code: Tolerance. E.g.: D=±0.5%      F=±1%      G=±2%      J=±5%

2.4 8<sup>th</sup>~11<sup>th</sup> codes: Resistance value.

2.4.1 If value belongs to standard value of E-24 series, the 8<sup>th</sup> code is zero, 9<sup>th</sup>~10<sup>th</sup> codes are the significant figures of resistance value, and the 11<sup>th</sup> code is the power of ten.

2.4.2 If value belongs to standard value of E-96 series, the 8<sup>th</sup>~10<sup>th</sup> codes are the significant figures of resistance value, and the 11<sup>th</sup> code is the power of ten.

2.4.3 11<sup>th</sup> codes listed as following:

0=10<sup>0</sup>    1=10<sup>1</sup>    2=10<sup>2</sup>    3=10<sup>3</sup>    4=10<sup>4</sup>    5=10<sup>5</sup>    6=10<sup>6</sup>    J=10<sup>-1</sup>    K=10<sup>-2</sup>    L=10<sup>-3</sup>    M=10<sup>-4</sup>    N=10<sup>-5</sup>    P=10<sup>-6</sup>

2.5 12<sup>th</sup>~14<sup>th</sup> codes.

2.5.1 12<sup>th</sup> code: Packaging Type. E.g.: T=Tape/Reel

2.5.2 13<sup>th</sup> code: Standard Packing Quantity.

4=4,000pcs      5=5,000pcs      C=10,000pcs      D=20,000pcs      E=15,000pcs

2.5.3 14<sup>th</sup> code: Special features.

E = standard

## 3. Ordering Procedure

(Example: 0805 1/8W ±5% 10KΩ T/R-5000)

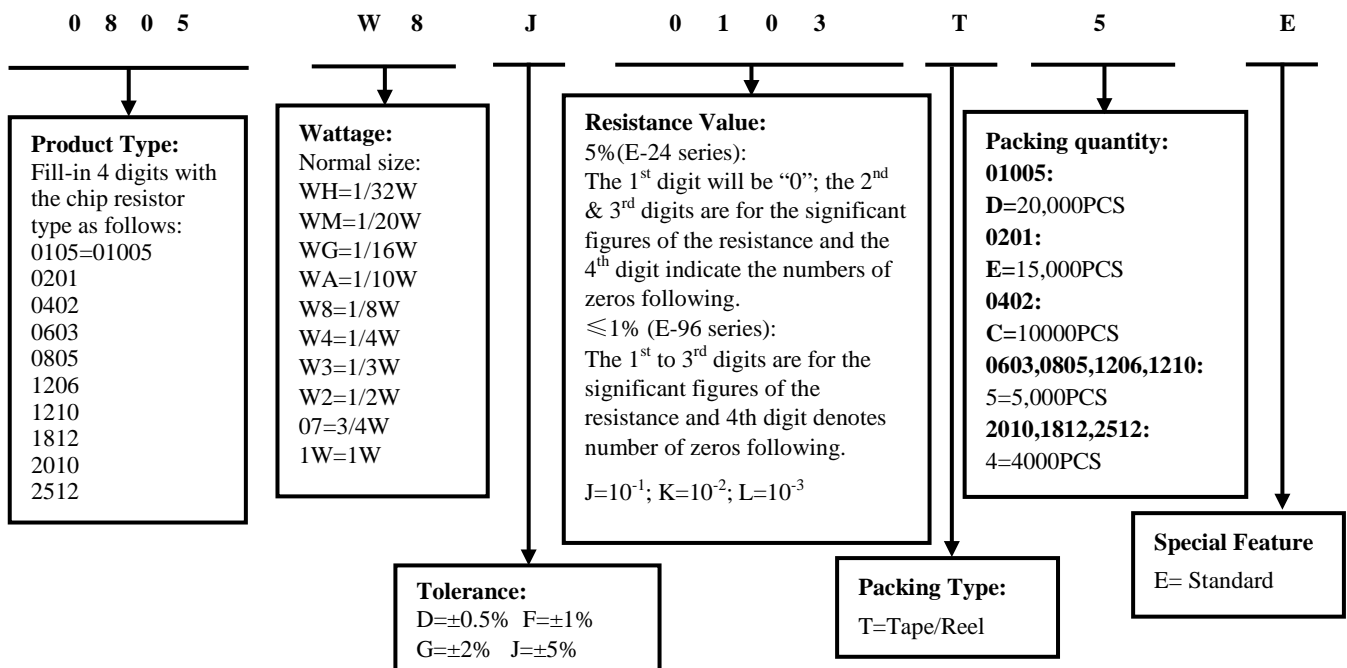

## 4. Marking

4.1 For 01005, 0201 and 0402 size. Due to the very small size of the resistor's body, there is no marking on the body.



4.2 Normally, the marking of 0Ω 0603, 0Ω 0805, 0Ω 1206, 0Ω 1210, 0Ω 1812, 0Ω 2010, 0Ω 2512 resistors as following



4.3 ±5% tolerance products (E-24 series):  
3 codes.  
1<sup>st</sup>~2<sup>nd</sup> codes are the significant figures of resistance value, and the rest code is the power of ten.



333 → 33KΩ

4.4 ±0.5%±1% tolerance products (E-96 series):  
4 codes.  
1<sup>st</sup>~3<sup>rd</sup> codes are the significant figures of resistance value, and the rest code is the power of ten.  
Letter "R" in mark means decimal point.



2701 → 2.7KΩ

4.5 More than 0805 specifications (including) 4 digits,  
Product below 1Ω, show as following, the first digit is "R" which as decimal point.



R300 → 0.3Ω

4.6 Standard E-96 series values of 0603 ≤1% : due to the small size of the resistor's body, 3 digits marking will be used to indicate the accurate resistance value by using the following multiplier & resistance code.

Multiplier Code (for 0603 ≤±1% marking)

Code	A	B	C	D	E	F	G	H	X	Y	Z
Multiplier	10 <sup>0</sup>	10 <sup>1</sup>	10 <sup>2</sup>	10 <sup>3</sup>	10 <sup>4</sup>	10 <sup>5</sup>	10 <sup>6</sup>	10 <sup>7</sup>	10 <sup>-1</sup>	10 <sup>-2</sup>	10 <sup>-3</sup>

Standard E-96 series Resistance Value code (for 0603 ≤±1% marking)

Value	Code	Value	Code	Value	Code	Value	Code
100	01	178	25	316	49	562	73
102	02	182	26	324	50	576	74
105	03	187	27	332	51	590	75
107	04	191	28	340	52	604	76
110	05	196	29	348	53	619	77
113	06	200	30	357	54	634	78
115	07	205	31	365	55	649	79
118	08	210	32	374	56	665	80
121	09	215	33	383	57	681	81
124	10	221	34	392	58	698	82
127	11	226	35	402	59	715	83
130	12	232	36	412	60	732	84
133	13	237	37	422	61	750	85
137	14	243	38	432	62	768	86
140	15	249	39	442	63	787	87
143	16	255	40	453	64	806	88
147	17	261	41	464	65	825	89
150	18	267	42	475	66	845	90
154	19	274	43	487	67	866	91
158	20	280	44	499	68	887	92
162	21	287	45	511	69	909	93
165	22	294	46	523	70	931	94
169	23	301	47	536	71	953	95
174	24	309	48	549	72	976	96

So the resistance value are marked as the following examples



$$1.96\text{K}\Omega = 196 \times 10^1 \Omega = 29\text{B}$$



$$12.4\Omega = 124 \times 10^{-1} \Omega = 10\text{X}$$

4.7 Standard E-24 and not belong to E-96 series values ( $\leq \pm 1\%$ ) of 0603 size: the marking is the same as 5% tolerance but marking as underline.



$$\underline{333} = 33\text{K}\Omega$$



$$\underline{680} = 68\Omega$$

## 5. Dimension

Type	Dimension(mm)				
	L	W	H	A	B
01005	0.40±0.02	0.20±0.02	0.13±0.02	0.10±0.03	0.10±0.03
0201	0.60±0.03	0.30±0.03	0.23±0.03	0.10±0.05	0.15±0.05
0402	1.00±0.10	0.50±0.05	0.35±0.05	0.20±0.10	0.25±0.10
0603	1.60±0.15	0.80±0.10	0.45±0.10	0.30±0.20	0.30±0.20
0805	2.00±0.15	1.25+0.15/-0.10	0.55±0.10	0.40±0.20	0.40±0.20
1206	3.10±0.15	1.55 +0.15/-0.10	0.55±0.10	0.45±0.20	0.45±0.20
1210	3.10±0.10	2.50±0.15	0.55±0.10	0.50±0.25	0.50±0.20
1812	4.50±0.20	3.20±0.20	0.55±0.20	0.50±0.20	0.50±0.20
2010	5.00±0.10	2.50±0.20	0.55±0.10	0.60±0.25	0.50±0.20
2512	6.35±0.10	3.20±0.20	0.55±0.10	0.60±0.25	0.50±0.20

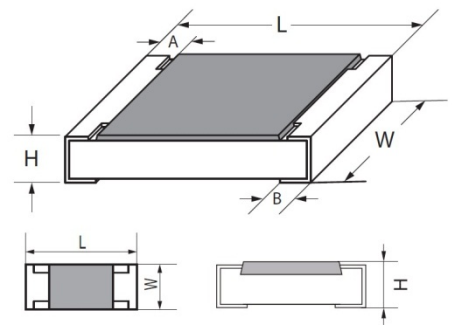

## 6. Resistance Range

Type	Power Rating	Resistance Range			
		±0.5%	±1.0%	±2.0%	±5.0%
01005	1/32W	---	1Ω-10MΩ	1Ω-10MΩ	1Ω-10MΩ
0201	1/20W	1Ω-10MΩ	1Ω-10MΩ	1Ω-10MΩ	1Ω-10MΩ
0402	1/16W	1Ω-10MΩ	0.1Ω-10MΩ	0.1Ω-10MΩ	0.1Ω-10MΩ
0603	1/10W	1Ω-10MΩ	0.01Ω-10MΩ	0.01Ω-10MΩ	0.01Ω-10MΩ
0805	1/8W	1Ω-10MΩ	0.1Ω≤R≤10MΩ	0.1Ω≤R≤10MΩ	0.1Ω≤R≤10MΩ
	1/4W	---	0.01Ω≤R<0.1Ω	0.01Ω≤R<0.1Ω	0.01Ω≤R<0.1Ω
1206	1/4W	1Ω-10MΩ	0.1Ω≤R≤10MΩ	0.1Ω≤R≤10MΩ	0.1Ω≤R≤10MΩ
	1/3W	---	0.01Ω≤R<0.1Ω	0.01Ω≤R<0.1Ω	0.01Ω≤R<0.1Ω
1210	1/2W	1Ω-10MΩ	0.01Ω-10MΩ	0.01Ω-10MΩ	0.01Ω-10MΩ
1812	3/4W	1Ω-10MΩ	0.01Ω-10MΩ	0.01Ω-10MΩ	0.01Ω-10MΩ
2010	3/4W	1Ω-10MΩ	0.01Ω-10MΩ	0.01Ω-10MΩ	0.01Ω-10MΩ
2512	1W	1Ω-10MΩ	0.01Ω-10MΩ	0.01Ω-10MΩ	0.01Ω-10MΩ

## 7. Ratings

Type	Max. Working Voltage	Max. Overload Voltage	Dielectric withstanding Voltage	Resistance Value of Jumper	Rated Current of Jumper	Max. Overload Current of Jumper	Operating Temperature
01005	15V	30V	--	<50mΩ	0.5A	1A	-55°C~125°C
0201	25V	50V	50V	<50mΩ	0.5A	1A	-55°C~155°C
0402	50V	100V	100V	<50mΩ	1A	2A	-55°C~155°C
0603	75V	150V	300V	<50mΩ	1A	2A	-55°C~155°C
0805	150V	300V	500V	<50mΩ	2A	5A	-55°C~155°C
1206	200V	400V	500V	<50mΩ	2A	10A	-55°C~155°C
1210	200V	500V	500V	<50mΩ	2A	10A	-55°C~155°C
1812	200V	500V	500V	<50mΩ	2A	10A	-55°C~155°C
2010	200V	500V	500V	<50mΩ	2A	10A	-55°C~155°C
2512	200V	500V	500V	<50mΩ	2A	10A	-55°C~155°C

\* Note: The measurement position of the 0Ω resistance value should be based on the positive electrode

## 8. Derating Curve

Power rating will change based on continuous load at ambient temperature from -55 to 155°C or 125°C. It is constant between -55 to 70°C, and derate to zero when temperature rise from 70 to 155°C or 125°C.

Voltage rating:

Resistors shall have a rated direct-current (DC) continuous working voltage or an approximate sine-wave root-mean-square (RMS) alternating-current (AC) continuous working voltage at commercial-line frequency and waveform corresponding to the power rating, as determined from the following formula:

$$RCWV = \sqrt{P \times R}$$

Remark: RCWV: Rating Continuous Working Voltage (Volt.) P: power rating (Watt) R: nominal resistance (Ω)

In no case shall the rated DC or RMS AC continuous working voltage be greater than the applicable maximum value.

The overload voltage is 2.5 times RCWV or Max. Overload voltage whichever is lower.

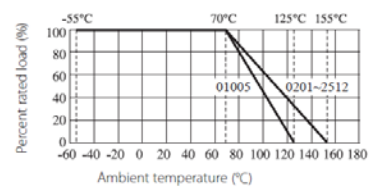

## 9. Structure

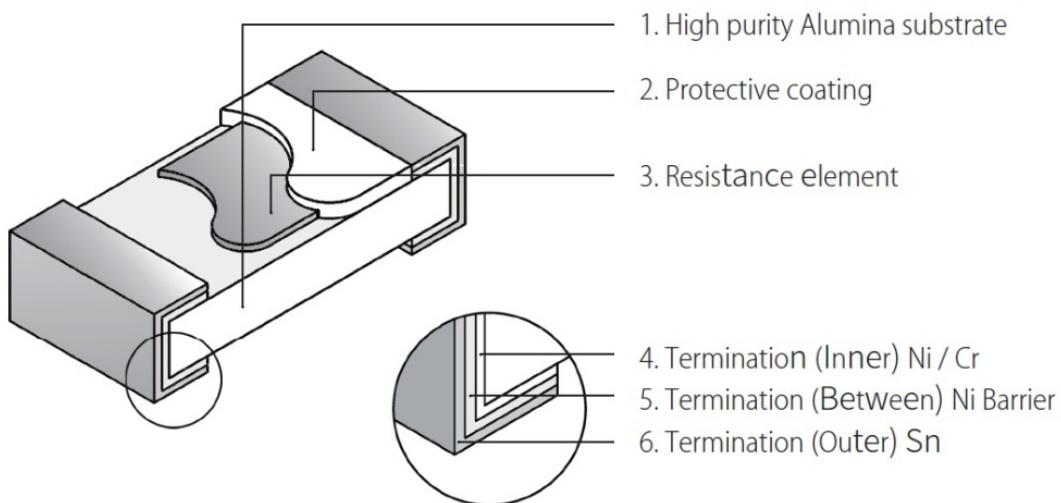



◎ *Low Temperature Storage	±0.5%, ±1% : ±(1.0%+0.05Ω)	IEC 60068-2-1 (Aa) Lower limit temperature ∅ for 2H.
	±2%, ±5% : ±(3.0%+0.05Ω)	
	01005: ±(3.0%+0.05Ω)	
	* <50mΩ	
◎ *High Temperature Exposure	±0.5%, ±1% : ±(1.0%+0.05Ω)	MIL-STD-202 108A Upper limit temperature ∅ for 1000H.
	±2%, ±5% : ±(3.0%+0.05Ω)	
	01005: ±(3.0%+0.05Ω)	
	* <50mΩ	
◎ *Leaching	No visible damage	J-STD-002 Test D Samples completely immersed for 30 sec in solder bath at 260 °C.

The resistors of 0Ω only can do the characteristic noted of \*

The resistors of 01005 & 0201 only can do the characteristic noted of ◎

## 11. Soldering Condition

(This is for recommendation, please customer perform adjustment according to actual application)

11.1 Recommend Reflow Soldering Profile : (solder : Sn96.5 / Ag3 / Cu0.5)

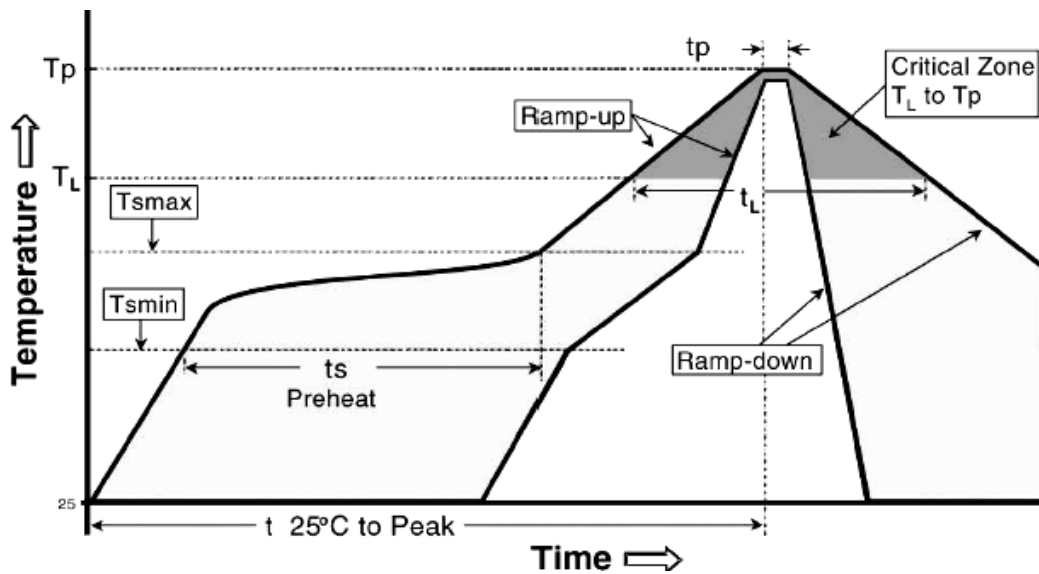

Profile Feature	Lead (Pb)-Free solder
Preheat:	
Temperature Min (Ts <sub>min</sub> )	150°C
Temperature Max (Ts <sub>max</sub> )	200°C
Time (Ts <sub>min</sub> to Ts <sub>max</sub> ) (ts)	60 -120 seconds
Average ramp-up rate : (Ts max to Tp)	3°C / second max.
Time maintained above :	
Temperature (T <sub>l</sub> )	217°C
Time (t <sub>l</sub> )	60-150 seconds
Peak Temperature (Tp)	260°C
Time within $\begin{matrix} +0 \\ -5 \end{matrix}$ °C of actual peak Temperature (tp) <sup>2</sup>	10 seconds
Ramp-down Rate	6°C/second max.
Time 25°C to Peak Temperature	8minutes max.

Allowed Re-flow times : 2 times

Remark : To avoid discoloration phenomena of chip on terminal electrodes, we suggest use N<sub>2</sub> Re-flow furnace .

## 11.2 Recommend Wave Soldering Profile : (Apply to 0603 and above size)

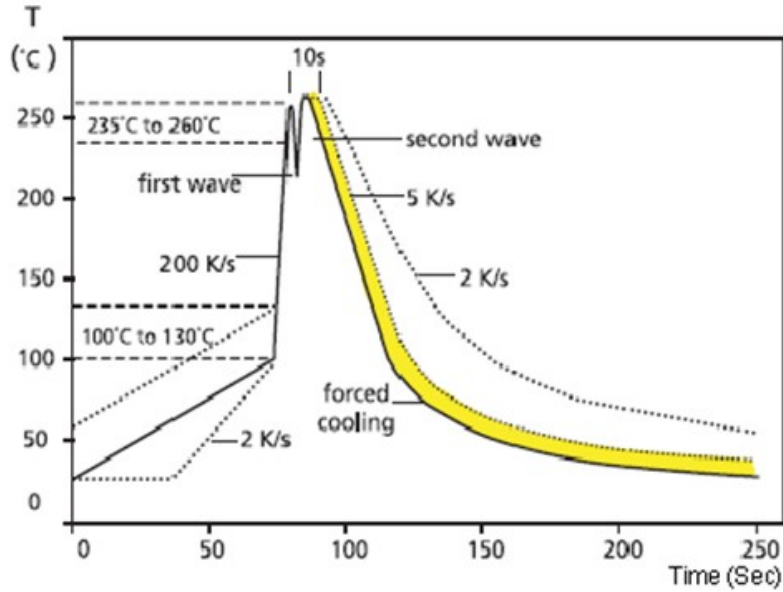

## 11.3 Soldering pad size recommended

Type	Dimension(mm)			
	A	B	C	D
01005	0.14±0.03	0.2±0.03	0.2±0.03	0.54±0.03
0201	0.25±0.05	0.35±0.05	0.4±0.05	1.0±0.05
0402	0.50±0.05	0.45±0.05	0.5±0.05	1.4±0.05
0603	0.9±0.05	0.65±0.05	0.8±0.05	2.1±0.05
0805	1.0±0.1	1.0±0.1	1.3±0.1	3.0±0.1
1206	2.0±0.1	1.1±0.1	1.6±0.1	4.2±0.1
1210	2.0±0.1	1.1±0.1	2.6±0.1	4.2±0.1
1812	3.2±0.1	1.4±0.1	3.3±0.1	5.8±0.1
2010	3.6±0.1	1.3±0.1	2.6±0.1	6.2±0.1
2512	5.0±0.1	1.6±0.1	3.3±0.1	8.2±0.1

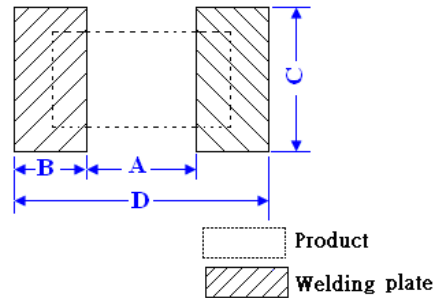

## 12. Packing

### 12.1 Dimension of Paper Taping:(Unit: mm)

Type	A	B	C ±0.05	$\Phi D_{-0}^{+0.1}$	E ±0.1	F ±0.05	G ±0.1	W ±0.2	T
01005	0.24±0.05	0.45±0.05	2.00	1.50	1.75	3.50	4.00	8.00	0.40±0.1
0201	0.40±0.05	0.70±0.05	2.00	1.50	1.75	3.50	4.00	8.00	0.42±0.1
0402	0.65±0.10	1.20±0.10	2.00	1.50	1.75	3.50	4.00	8.00	0.42±0.05

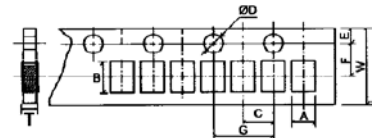

Type	A ±0.2	B ±0.2	C ±0.05	$\Phi D_{-0}^{+0.1}$	E ±0.1	F ±0.05	G ±0.1	W ±0.2	T ±0.1
0603	1.10	1.90	2.00	1.50	1.75	3.50	4.00	8.00	0.67
0805	1.65	2.40	2.00	1.50	1.75	3.50	4.00	8.00	0.81
1206	2.00	3.60	2.00	1.50	1.75	3.50	4.00	8.00	0.81
1210	2.80	3.50	2.00	1.50	1.75	3.50	4.00	8.00	0.75

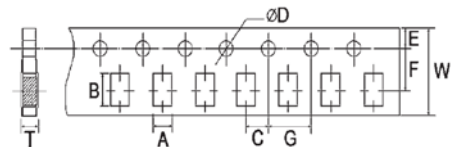

### 12.2 Dimension of plastic taping: (Unit: mm)

Type	A ±0.2	B ±0.2	C ±0.05	$\Phi D_{-0}^{+0.1}$	$\Phi D1_{-0}^{+0.25}$	E ±0.1	F ±0.05	G ±0.1	W ±0.2	T ±0.1
2010	2.90	5.60	2.00	1.50	1.50	1.75	5.50	4.00	12.00	1.00
1812	3.50	4.80	2.00	1.50	1.50	1.75	5.50	4.00	12.00	1.00
2512	3.50	6.70	2.00	1.50	1.50	1.75	5.50	4.00	12.00	1.00

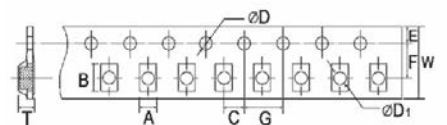

## 12.3 Dimension of Reel : (Unit: mm)

Type	Taping	Qty/Reel	A ±0.5	B ±0.5	C ±0.5	D ±1	M ±2	W ±1
01005	Paper	20,000pcs	2.0	13.0	21.0	60.0	178.0	10.0
0201	Paper	15,000pcs	2.0	13.0	21.0	60.0	178.0	10.0
0402	Paper	10,000pcs	2.0	13.0	21.0	60.0	178.0	10.0
0603	Paper	5,000pcs	2.0	13.0	21.0	60.0	178.0	10.0
0805	Paper	5,000pcs	2.0	13.0	21.0	60.0	178.0	10.0
1206	Paper	5,000pcs	2.0	13.0	21.0	60.0	178.0	10.0
1210	Paper	5,000pcs	2.0	13.0	21.0	60.0	178.0	10.0
2010	Embossed	4,000pcs	2.0	13.0	21.0	60.0	178.0	13.8
1812	Embossed	4,000pcs	2.0	13.0	21.0	60.0	178.0	13.8
2512	Embossed	4,000pcs	2.0	13.0	21.0	60.0	178.0	13.8

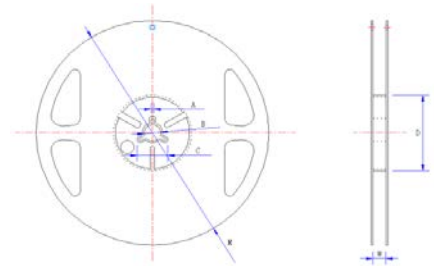

## 13. Note

- 13.1 UNI-ROYAL recommend products store in warehouse with temperature between 15 to 35°C under humidity between 25 to 75%RH. Even under storage conditions recommended above, solder ability of products will be degraded stored over 1 year old.
- 13.2 Cartons must be placed in correct direction which indicated on carton, otherwise the reel or wire will be deformed.
- 13.3 Storage conditions as below are inappropriate:
- Stored in high electrostatic environment
  - Stored in direct sunshine, rain, snow or condensation.
  - Exposed to sea wind or corrosive gases, such as Cl<sub>2</sub>, H<sub>2</sub>S, NH<sub>3</sub>, SO<sub>2</sub>, NO<sub>2</sub>, Br etc.
- 13.4. The products are used in circuit board thickness greater than 1.6mm. If customers use less than the thickness of the circuit board that you should confirm with the company, in order to recommend a more suitable product.

## 14. Record

Version	Description	Page	Date	Amended by	Checked by
1	First version	1~7	Mar.20, 2018	Haiyan Chen	Nana Chen
2	Modify 0201 packing quantity	7	May.24, 2018	Haiyan Chen	Nana Chen
3	1. Add 0603 code mark 2. Modify the operating temperature of 01005 3. Modify characteristic	3~4 5 6~7	Feb.12, 2019	Haiyan Chen	Yuhua Xu
4	Modify the High Temperature Exposure conditions	7	July.29, 2019	Haiyan Chen	Yuhua Xu
5	Modify the reflow curve and add the wave soldering curve	7~8	Apr.22, 2020	Haiyan Chen	Yuhua Xu
6	Add the Alloy Film Resistance Range and Ordering Procedure	4 2	Sep.05, 2022	Haiyan Chen	Yuhua Xu
7	Modify the temperature coefficient test conditions	6	Oct.13, 2022	Haiyan Chen	Yuhua Xu
8	Modify the "W" dimension of 1210	4	Apr.28, 2025	Haiyan Chen	Yuhua Xu
9	Modify the resistance value range of 01005and 0402 Add the resistance range of 0201 by 0.5%	4	Jun.21, 2025	Haiyan Chen	Yuhua Xu
10	Add the 0201 dielectric withstanding voltage	5	Jul.28, 2025	Haiyan Chen	Yuhua Xu
11	Modify the dimensional tolerance of the 0603"L" value	4	Mar.17, 2026	Haiyan Chen	Yuhua Xu

© Uniroyal Electronics Global Co., Ltd. All rights reserved. Specification herein will be changed at any time without prior notice.