

# DATASHEET

**Product Name** Wire-Wound Fixed Resistors

---

**Part Name** KNP Series

**File No.** DIP-SP-008

## **Uniroyal Electronics Global Co., Ltd.**

88#, Longteng Road, Economic & Technical Development Zone, Kunshan, Jiangsu, China

Tel +86 512 5763 1411 / 22 /33

Email [marketing@uni-royal.cn](mailto:marketing@uni-royal.cn)

Manufacture Plant Uniroyal Electronics Industry Co., Ltd.

Aeon Technology Corporation

Royal Electronic Factory (Thailand) Co., Ltd.

Royal Technology (Thailand) Co., Ltd.

## 1. Scope

- 1.1 This datasheet is the characteristics of Wire-Wound Fixed Resistors manufactured by UNI-ROYAL.
- 1.2 Excellent flame retardant coating
- 1.3 Too low or too high ohmic value can be supplied on a case to basis
- 1.4 Non-inductive type available
- 1.5 Compliant with RoHS directive.
- 1.6 Halogen free requirement.

## 2. Part No. System

The standard Part No. includes 14 digits with the following explanation:

- 2.1 Wire-Wound Fixed Resistors type, the 1<sup>st</sup> to 3<sup>rd</sup> digits are to indicate the product type and 4<sup>th</sup> digit is the special feature.

Example:

KNP= Wire-Wound Fixed Resistors type.

- 2.2 5<sup>th</sup>~6<sup>th</sup> digits:

- 2.2.1 This is to indicate the wattage or power rating. To dieting the size and the numbers,

The following codes are used; and please refer to the following chart for detail:

W=Normal Size; S=Small Size; U=Extra Small Size; “1”~“G”to denotes“1”~“16”as Hexadecimal:

1/16W~1/2W (< 1W )

Wattage	1/2	1/3	1/4	1/5	1/6	1/8	1/10	1/16
Normal Size	W2	W3	W4	W5	W6	W8	WA	WG
Small Size	S2	S3	S4	S5	S6	S8	SA	SG

1W~16W (≥ 1W )

Wattage	1	2	3	5	7	8	9	10	15
Normal Size	1W	2W	3W	5W	7W	8W	9W	AW	FW
Small Size	1S	2S	3S	5S	7S	8S	9S	AS	FS

- 2.2.2 For power rating less than 1 watt, the 5<sup>th</sup> digit will be the letters W, S or U to represent the size required & the 6<sup>th</sup> digit will be a number or a letter code.

Example: WA=1/10W; U2=1/2W-SS.

- 2.2.3 For power of 1 watt to 16 watt, the 5<sup>th</sup> digit will be a number or a letter code and the 6<sup>th</sup> digit will be the letters of W, S or U.

Example: AW=10W; 3S=3W-S

- 2.3 The 7<sup>th</sup> digit is to denote the Resistance Tolerance. The following letter code is to be used for indicating the standard Resistance Tolerance.

F=±1% G=±2% J=±5% K= ±10%

- 2.4 The 8<sup>th</sup> to 11<sup>th</sup> digits is to denote the Resistance Value.

- 2.4.1 For the standard resistance values of E-24 series, the 8<sup>th</sup> digit is “0”,the 9<sup>th</sup> & 10<sup>th</sup> digits are to denote the significant figures of the resistance and the 11<sup>th</sup> digit is the number of zeros following.;

For the standard resistance values of E-96 series, the 8<sup>th</sup> digit to the 10<sup>th</sup> digits is to denote the significant figures of the resistance and the 11<sup>th</sup> digit is the 11<sup>th</sup> digit is the zeros following.

- 2.4.2 The following number s and the letter codes are to be used to indicate the number of zeros in the 11<sup>th</sup> digit:

0=10<sup>0</sup> 1=10<sup>1</sup> 2=10<sup>2</sup> 3=10<sup>3</sup> 4=10<sup>4</sup> 5=10<sup>5</sup>  
6=10<sup>6</sup> J=10<sup>-1</sup> K=10<sup>-2</sup> L=10<sup>-3</sup> M=10<sup>-4</sup>

- 2.4.3 The 12<sup>th</sup>, 13<sup>th</sup> & 14<sup>th</sup> digits.

The 12<sup>th</sup> digit is to denote the Packaging Type with the following codes:

A=Tape/Box (Ammo pack) B=Bulk/Box

T=Tape/Reel P=Tape/Box of PT-26 products

- 2.4.4 The 13<sup>th</sup> digit is normally to indicate the Packing Quantity of Tape/Box & Tape/Reel packaging types. The following letter code is to be used for some packing quantities:

A=500pcs B=2500pcs C=10000pcs D=20000pcs G=25000pcs H=50000pcs

- 2.4.5 For the FORMED type products, the 13<sup>th</sup> & 14<sup>th</sup> digits are used to denote the forming types of the product with the following letter codes:

MF=M-type with flattened lead wire F0= F-type  
MK= M-type with kinked lead wire F1= F1-type  
ML= M-type with normal lead wire F2= F2-type  
MC= M-type with bending lead wire F3= F3-type

- 2.4.6 For some items, the 14<sup>th</sup> digit alone can use to denote special features of additional information with the following codes:

0=NIL P=Panasert type 1=Avisert type 1 2=Avisert type 2  
3=Avisert type 3 A=Cutting type CO 1/4W-A type B= Cutting type CO 1/4W-B type

### 3. Ordering Procedure

(Example: KNP 2W ±5% 100 Ω T/B-1000)

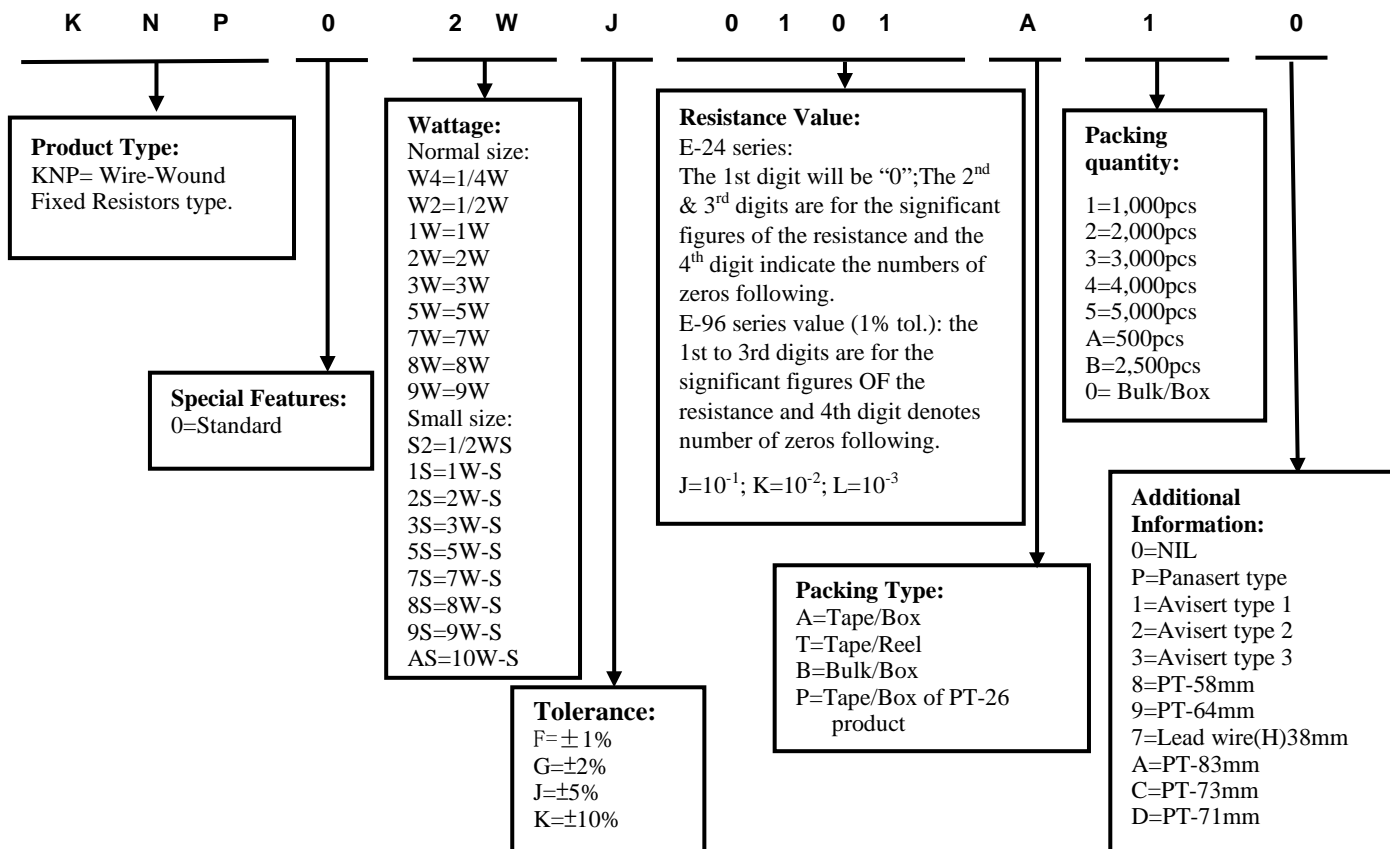

### 4. Color Code

Resistors shall be marked with color coding  
Colors shall be in accordance with JIS C 0802  
≥ ±2% Series

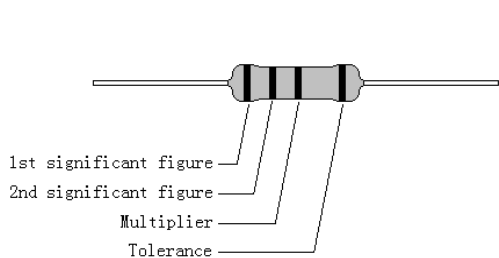

1st Band	2nd Band	3rd Band	4th Band
Black = 0	Black = 0	Black = Multiply by 1 (10 <sup>0</sup> )	Red = ±2%
Brown = 1	Brown = 1	Brown = Multiply by 10 (10 <sup>1</sup> )	Gold = ±5%
Red = 2	Red = 2	Red = Multiply by 100 (10 <sup>2</sup> )	Silver = ±10%
Orange = 3	Orange = 3	Orange = Multiply by 1,000 (10 <sup>3</sup> )	
Yellow = 4	Yellow = 4	Yellow = Multiply by 10,000 (10 <sup>4</sup> )	
Green = 5	Green = 5	Green = Multiply by 100,000 (10 <sup>5</sup> )	
Blue = 6	Blue = 6	Blue = Multiply by 1,000,000 (10 <sup>6</sup> )	
Violet = 7	Violet = 7	Violet = Multiply by 10,000,000 (10 <sup>7</sup> )	
Gray = 8	Gray = 8	Gold = Multiply by 0.1 (10 <sup>-1</sup> )	
White = 9	White = 9	Silver = Multiply by 0.01 (10 <sup>-2</sup> )	

±1% Series

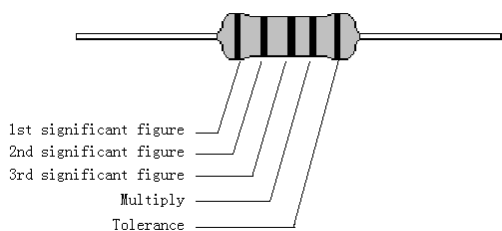

1st Band	2nd Band	3rd Band	4th Band	5th Band
Black = 0	Black = 0	Black = 0	Black = Multiply by 1 (10 <sup>0</sup> )	Brown = ±1%
Brown = 1	Brown = 1	Brown = 1	Brown = Multiply by 10 (10 <sup>1</sup> )	
Red = 2	Red = 2	Red = 2	Red = Multiply by 100 (10 <sup>2</sup> )	
Orange = 3	Orange = 3	Orange = 3	Orange = Multiply by 1,000 (10 <sup>3</sup> )	
Yellow = 4	Yellow = 4	Yellow = 4	Yellow = Multiply by 10,000 (10 <sup>4</sup> )	
Green = 5	Green = 5	Green = 5	Green = Multiply by 100,000 (10 <sup>5</sup> )	
Blue = 6	Blue = 6	Blue = 6	Blue = Multiply by 1,000,000 (10 <sup>6</sup> )	
Violet = 7	Violet = 7	Violet = 7	Violet = Multiply by 10,000,000 (10 <sup>7</sup> )	
Gray = 8	Gray = 8	Gray = 8	Gold = Multiply by 0.1 (10 <sup>-1</sup> )	
White = 9	White = 9	White = 9	Silver = Multiply by 0.01 (10 <sup>-2</sup> )	

Remark: For ultra-low resistance, the above method can not be expressed, with the following color ring identification

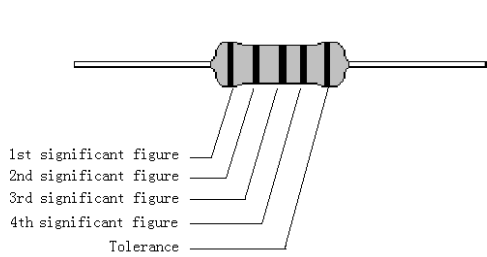

1 <sup>st</sup> Band	2 <sup>nd</sup> Band	3 <sup>rd</sup> Band	4 <sup>th</sup> Band	5 <sup>th</sup> Band
Black = 0	Black = 0	Black = 0	Black = 0	Brown = ±1%
Brown = 1	Brown = 1	Brown = 1	Brown = 1	Red 紅 = ±2%
Red = 2	Red = 2	Red = 2	Red = 2	Gold 金 = ±5%
Orange = 3	Orange = 3	Orange = 3	Orange = 3	Silver 銀 = ±10%
Yellow = 4	Yellow = 4	Yellow = 4	Yellow = 4	
Green = 5	Green = 5	Green = 5	Green = 5	
Blue = 6	Blue = 6	Blue = 6	Blue = 6	
Violet = 7	Violet = 7	Violet = 7	Violet = 7	
Gray = 8	Gray = 8	Gray = 8	Gray = 8	
White = 9	White = 9	White = 9	White = 9	

#### 4.1 Label:

Label shall be marked with following items:

- (1) Type and style
- (2) Nominal resistance
- (3) Resistance tolerance
- (4) Quantity
- (5) Lot number
- (6) PPM

#### Example:

WIRE-WOUND FIXED RESISTORS	
WATT : 1W	VAL: 1Ω
Q'TY: 1000	TOL: 5%
LOT: 5021528	PPM:

Shall be prevailed in kind!

## 5. Ratings & Dimension

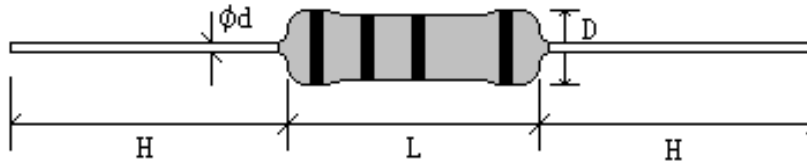

Type	Dimension(mm)					Tolerance	Resistance Range
	D±1	L±1	d±0.05	H±3	PT		
KNP 1/4W	2.5	6.5	0.54	28	52	±1%、±2%、±5%、±10%	0.01Ω~200Ω
KNP 1/2WS	2.5	6.5	0.54	28	52	±1%、±2%、±5%、±10%	0.01Ω~200Ω
KNP 1/2W	3.0	9.5	0.54	28	52	±1%、±2%、±5%、±10%	0.01Ω~390Ω
KNP 1WS	3.0	9.5	0.54	28	52	±1%、±2%、±5%、±10%	0.01Ω~390Ω
KNP 1W	4.5	11.5	0.70	25	52	±1%、±2%、±5%、±10%	0.01Ω~1.2KΩ
KNP 2WS	4.5	11.5	0.70	25	52	±1%、±2%、±5%、±10%	0.01Ω~1.2KΩ
KNP 2W	5.5	15.5	0.70	28	64	±1%、±2%、±5%、±10%	0.01Ω~3.0KΩ
KNP 3WS	5.5	15.5	0.70	28	64	±1%、±2%、±5%、±10%	0.01Ω~3.0KΩ
KNP 3W	6.5	17.5	0.75	28	64	±1%、±2%、±5%、±10%	0.039Ω~3.9KΩ
KNP 5WS	6.5	17.5	0.75	28	64	±1%、±2%、±5%、±10%	0.039Ω~3.9KΩ
KNP 5W	8.5	24.5	0.75	38	90&B/B	±1%、±2%、±5%、±10%	0.082Ω~5.6KΩ
KNP 7WS	8.5	24.5	0.75	38	90&B/B	±1%、±2%、±5%、±10%	0.082Ω~5.6KΩ
KNP 7W	8.5	29.5	0.75	38	B/B	±1%、±2%、±5%、±10%	0.1Ω~8.2KΩ
KNP 8WS	8.5	29.5	0.75	38	B/B	±1%、±2%、±5%、±10%	0.1Ω~8.2KΩ
KNP 8W	8.5	39.5	0.75	38	B/B	±1%、±2%、±5%、±10%	0.15Ω~12KΩ
KNP 9WS	8.5	39.5	0.75	38	B/B	±1%、±2%、±5%、±10%	0.15Ω~12KΩ
KNP 9W	8.5	52.5	0.75	38	B/B	±1%、±2%、±5%、±10%	0.22Ω~15KΩ
KNP 10WS	8.5	52.5	0.75	38	B/B	±1%、±2%、±5%、±10%	0.22Ω~15KΩ

## 6. Derating Curve

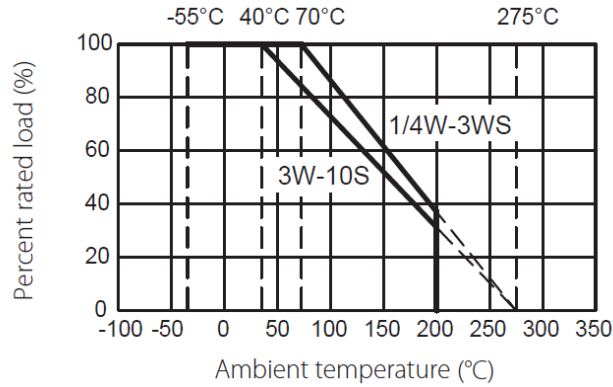

### 6.1 Voltage rating:

Resistors shall have a rated direct-current (DC) continuous working voltage or an approximate sine-wave root-mean-square (RMS) alternating-current (AC) continuous working voltage at commercial-line frequency and waveform corresponding to the power rating, as determined from the following formula:

$$RCWV = \sqrt{P \times R}$$

Where: RCWV = rated dc or RMS ac continuous working voltage at commercial-line frequency and waveform (VOLT.)

P = power rating (WATT.)

R = nominal resistance (OHM)

## 7. Structure

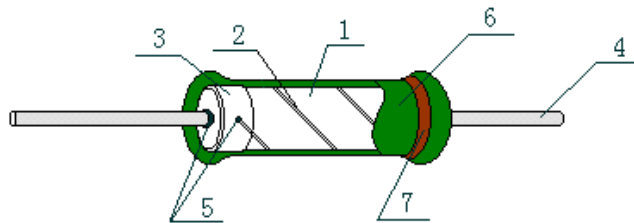

No.	Name	Raw materials
1	Basic body	Rod Type Ceramics
2	Resistor	Alloys
3	End cap	Steel (Tin Plated iron Surface)
4	Lead wire	Tin solder coated copper wire
5	Joint	By welding
6	Coating	Normal size & Insulated Non-Flame Paint Color: Deep Green (Normal size) Light Green (small size)
7	Marking	Epoxy Resin

## 8. Performance Specification

Characteristic	Limits	Test Methods (GB/T5729&JIS-C-5201&IEC60115-1)
Temperature Coefficient	$\geq 20\Omega: \pm 300\text{PPM}/^\circ\text{C}$ $< 20\Omega: \pm 400\text{PPM}/^\circ\text{C}$	4.8 Natural resistance changes per temp. Degree centigrade $\frac{R_2 - R_1}{R_1(t_2 - t_1)} \times 10^6 \text{ (PPM}/^\circ\text{C)}$ $R_1$ : Resistance Value at room temperature ( $t_1$ ) ; $R_2$ : Resistance at test temperature ( $t_2$ ) $t_1$ : +25°C or specified room temperature $t_2$ : Test temperature (-55°C or 125°C)
Short-Time Overload	$\Delta R/R \leq \pm(2\% + 0.05 \Omega)\text{Max}$ , with no evidence of mechanical damage	4.13 Permanent resistance change after the application of a potential of 2.5 times RCWV or Max.Overload Votage whichever less for 5 seconds.
Terminal strength	No evidence of mechanical damage	4.16 Direct load: Resistance to a 2.5 kg direct load for 10 seconds in the direction of the longitudinal axis of the terminal leads. Twist test: Terminal leads shall be bent through 90° at a point of about 6mm from the body of the resistor and shall be rotated through 360° about the original axis of the bent terminal in alternating direction for a total of 3 rotations.
Resistance to soldering heat	Resistance change rate is: $\pm (1\% + 0.05\Omega)$ Max. With no evidence of mechanical damage	4.18 Permanent resistance change when leads immersed to a point 2.0-2.5mm from the body in 260°C±5°C solder for 10±1 seconds.
Solderability	95% Coverage Min.	4.17 The area covered with a new, smooth, clean, shiny and continuous surface free from concentrated pinholes. Temperature of solder: 245°C±3°C Dwell time in solder: 2~3seconds.
Load life in humidity	Resistance change rate is:±(5%+0.05Ω) Max.. With no evidence of mechanical damage.	7.9 Resistance change after 1000 hours (1.5hours “ON” , 0.5hours “OFF” ) at RCWV or Max.Working Voltage whichever less in a humidity test chamber controlled at 40±2° C and 93%±3% RH.
Load life	Resistance change rate is:±(5%+0.05Ω) Max.. With no evidence of mechanical damage.	4.25.1 Permanent Resistance change after 1000 hours operating at RCWV or Max.Working Voltage whichever less with duty cycle of 1.5 hours “ON” , 0.5 hour “OFF” at 70±2°C or 40±2°C ambient.
Low Temperature Storage	Resistance change rate is:±(5%+0.05Ω) Max.. With no evidence of mechanical damage.	IEC 60068-2-1 (Aa) Lower limit temperature , for 2H.
High Temperature Exposure	Resistance change rate is:±(5%+0.05Ω) Max.. With no evidence of mechanical damage.	MIL-STD-202 108A Upper limit temperature , for 16H.
Rapid change of temperature	Resistance change rate is: $\pm(2\% + 0.05\Omega)\text{Max}$ . With no evidence of mechanical damage.	4.19 30 min at -55 °C and 30 min at 155°C; 100 cycles.

## 9. Packing

### 9.1 Tapes in Box Packing

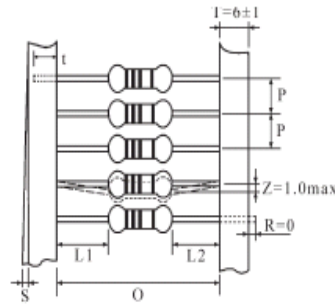
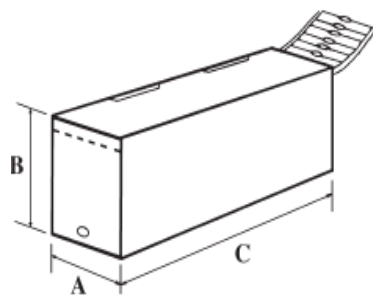

\*L1-L2=1.0 Max.  
 ZW: 0  
 \*\*S=0.5 Max.  
 PT-26: 0.8 Max.

Dimension of T/B (mm)

Part No.	O	P	A±5	B±5	C±5	Qty/Box
KNP 1/4W	52±1	5±0.3	75	116	255	5,000pcs
KNP 1/2WS	52±1	5±0.3	75	116	255	5,000pcs
KNP 1/2W	52±1	5±0.3	75	45	255	1,000pcs
KNP 1WS	52±1	5±0.3	75	45	255	1,000pcs
KNP 1W	52±1	5±0.3	80	82	255	1,000pcs
KNP 2WS	52±1	5±0.3	80	82	255	1,000pcs
KNP 2W	64±5	10±0.5	90	119	255	1,000pcs
KNP 3WS	64±5	10±0.5	90	119	255	1,000pcs
KNP 3W	64±5	10±0.5	90	88	255	500pcs
KNP 5WS	64±5	10±0.5	90	88	255	500pcs
KNP 5W	90±5	10±0.5	115	124	500	500pcs
KNP 7WS	90±5	10±0.5	115	124	500	500pcs

### 9.2 Tapes in Reel Packing

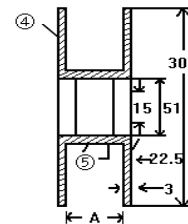
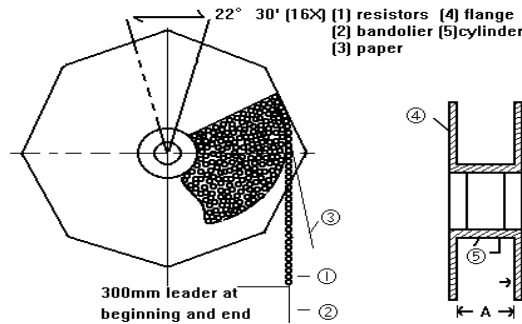
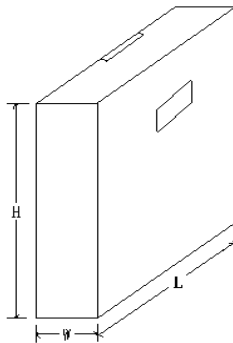

Dimension of Reel (mm)

Part No.	O	A	W±5	H±5	L±5	Qty/Box
KNP 1/4W	52±1	73±2	85	294	293	5,000pcs
KNP 1/2WS	52±1	73±2	85	294	293	5,000pcs
KNP 1/2W	52±1	73±2	85	294	293	4,000pcs
KNP 1WS	52±1	73±2	85	294	293	4,000pcs
KNP 1W	52±1	73±2	85	294	293	2,500pcs
KNP 2WS	52±1	73±2	85	294	293	2,500pcs
KNP 2W	64±5	80±5	95	294	293	1,000pcs
KNP 3WS	64±5	80±5	95	294	293	1,000pcs
KNP 3W	64±5	80±5	95	294	293	1,000pcs
KNP 5WS	64±5	80±5	95	294	293	1,000pcs
KNP 5W	90±5	115±5	110	310	310	700pcs
KNP 7WS	90±5	115±5	110	310	310	700pcs

## 9.3 Bulk in Box Packing

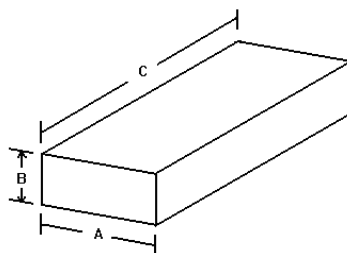

**Dimension of Box (mm)**

Part No.	A±5	B±5	C±5	Qty/Box
KNP 1/4W	140	80	240	500/10,000pcs
KNP 1/2WS	140	80	240	500/10,000pcs
KNP 1/2W	140	80	240	200/4,000pcs
KNP 1WS	140	80	240	200/4,000pcs
KNP 1W	140	80	240	100/2,500pcs
KNP 2WS	140	80	240	100/2,500pcs
KNP 2W	140	80	240	100/1,500pcs
KNP 3WS	140	80	240	100/1,500pcs
KNP 3W	140	80	240	100/1,000pcs
KNP 5WS	140	80	240	100/1,000pcs
KNP 5W	140	80	240	25/400pcs
KNP 7WS	140	80	240	25/400pcs
KNP 7W	140	80	240	25/300pcs
KNP 8WS	140	80	240	25/300pcs
KNP 8W	140	80	240	25/200pcs
KNP 9WS	140	80	240	25/200pcs
KNP 9W	140	80	240	25/200pcs
KNP 10WS	140	80	240	25/200pcs

## 10. Note

10.1 UNI-ROYAL recommend the storage condition temperature: 15°C~35°C, humidity :25%~75%.

(Put condition for individual product).

Even under UNI-ROYAL recommended storage condition, solderability of products over 1 year old. (Put condition for each product) may be degraded.

10.2 Store / transport cartons in the correct direction, which is indicated on a carton as a symbol.

Otherwise bent leads may occur due to excessive stress applied when dropping of a carton.

10.3 Product performance and soldered connections may deteriorate if the products are stored in the following places:

- Storage in high Electrostatic.
- Storage in direct sunshine、rain and snow or condensation.
- Where the products are exposed to sea winds or corrosive gases, including Cl<sub>2</sub>, H<sub>2</sub>S、NH<sub>3</sub>, SO<sub>2</sub>, NO<sub>2</sub>, Br etc.

## 11. Record

Version	Description	Page	Date	Amended by	Checked by
1	First version	1~7	Mar.20, 2018	Haiyan Chen	Nana Chen
2	1.Modify the Derating Curve 2. Modify characteristic	4 5~6	Feb.19, 2019	Haiyan Chen	Yuhua Xu
3	Modify the size of 8W to 10WS wires from "0.75" to "1.00"	4	Mar.15, 2022	Haiyan Chen	Yuhua Xu
4	Modify the temperature coefficient test conditions	5	Oct.28, 2022	Haiyan Chen	Yuhua Xu
5	1.Increased standard color code system 2.Add the 1% tolerance	3 3~4	Apr.01, 2024	Haiyan Chen	Yuhua Xu
6	Modify the ultra-low resistance color code	4	Mar.05,2025	Haiyan Chen	Yuhua Xu
7	Modify the packaging size and the number of packages	7~8	Jun.23, 2025	Haiyan Chen	Yuhua Xu
8	Modify the wire diameter	4	Mar.28, 2026	Haiyan Chen	Yuhua Xu